

PALLMANN

Double Stream Mill PSKM

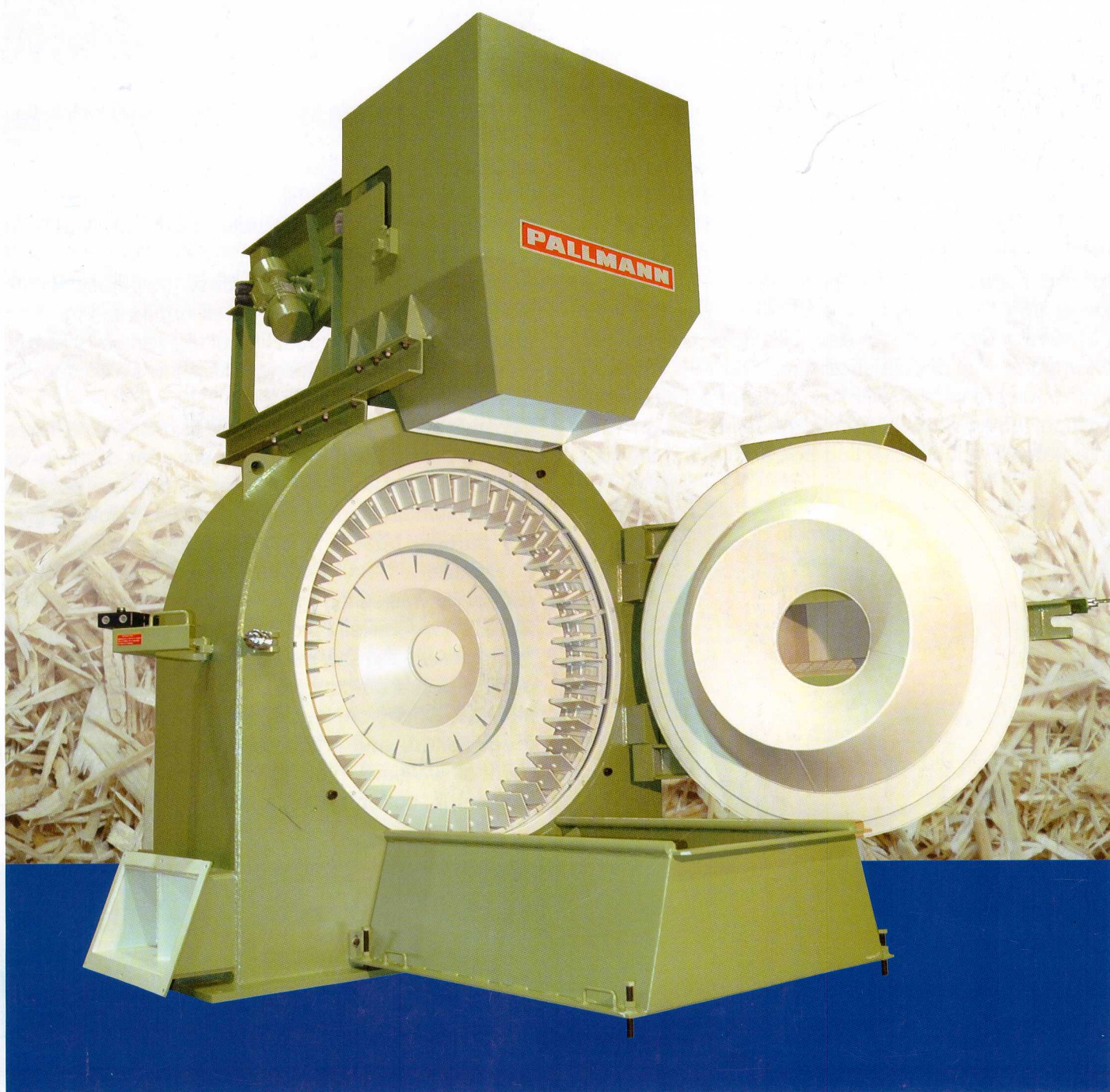

Double Stream Mill PSKM

Compact and sturdy – for long, trouble-free operation

Pallmann double stream mills PSKM are built for tough around-the-clock operation. Heavy, thick walled machine housings in fabricated design and a generously dimensioned bearing and drive arrangement guarantee smooth operation and a long service life. The bearing and drive system is flanged to the machine housing and can be easily exchanged as a compact premounted unit. The rotor is carefully stress relieved and electrodynamically balanced for smooth vibration-free operation. The grinding chamber is easily accessible through a large front door. As a standard item the scope of supply includes a slide to easily remove the grinding ring from the machine to the front. Additional lifting devices and dismantling of the impeller are not needed for exchange of the beeter plates.

Downtime for maintenance is essentially reduced because of this option for easy and quick changing of wear parts. The double stream mill PSKM is supplied in its standard version with finished product discharge straight downward. A special housing design with integrated product collecting box and lateral product



Infeed material



Final product

discharge is available too. This option allows installation of the machine without any additional support frame or costly concrete foundation and pit.

Homogeneous, finest particles from different feed Materials

Surface layer flakes are the basis for finest quality particle boards and better sales opportunities. The prerequisite for the production of high quality board is a uniform, thin flake material with a low percentage of dust and coarse particles.

Because of their ideal, slender shape, PSKM fine flakes are preferably used for smooth surfaces of three- or multiple layer and homogeneous particle boards. The outstanding glueing and spreading qualities give the particle board its high bending strength and guarantee a homogeneous fine surface which is especially well suited for further overlays. The PSKM flake is economically produced from planer shavings, milling flakes and saw dust as well as from precrushed particle board off-cuts and coarse particles from the air sifter. Of course, flakes from the knife ring or from drum flakers and chips can be used just as well. From all well known annual plants such as bagasse, miscanthus, cotton stalks, hemp stalks, corn and rice

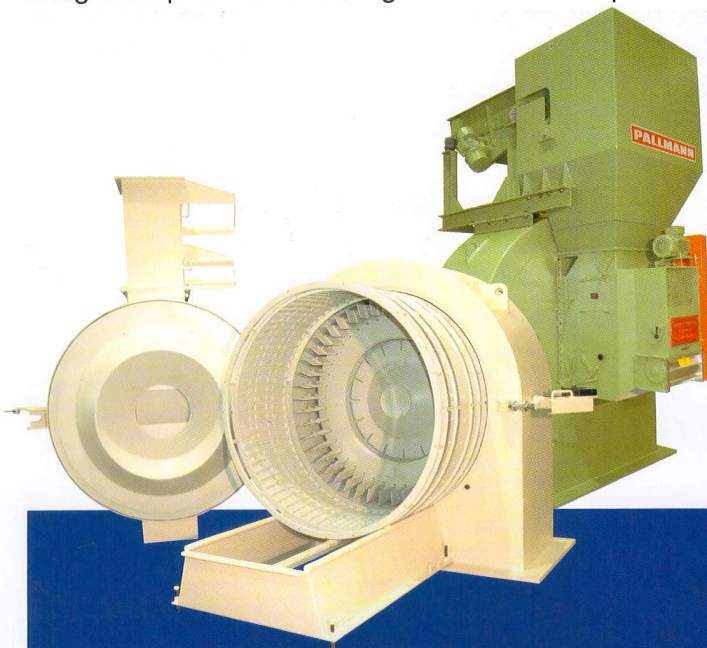

Double Stream Mill PSKM

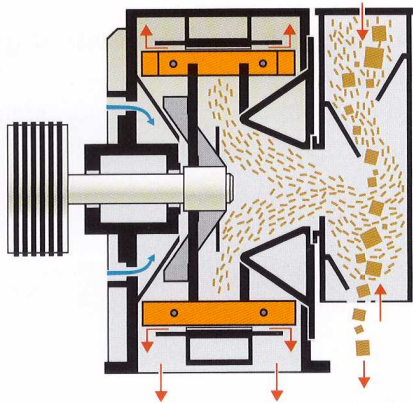

Diagram: Gravity separator feed chute for separation of heavy material

straw, etc. the double stream mill PSKM produces a fibrous raw material to be used for the production of boards. For many years several hundred Pallmann double stream mills have been in continuous three-shift operation in particle board plants all over the world. The experience gained in practical operation has led to continuous improvements of the design of this well proven machine. Today the double stream mill PSKM is the standard machine for economical preparation of surface material in board plants all over the world.

Pallmann PSKM, a superior System Grinding and Sifting in a single Operation

The fan effect of a multiple wing impeller pulls the feed material centrally into the grinding chamber passing through a special feed chute designed as a gravity separator for heavy material. An especially designed material guiding cone distributes the material evenly on the periphery and the entire width of the grinding track. The impeller, rotating at high speed, produces high air turbulence between the impeller wear plates the serrated profile of the grinding track. The double

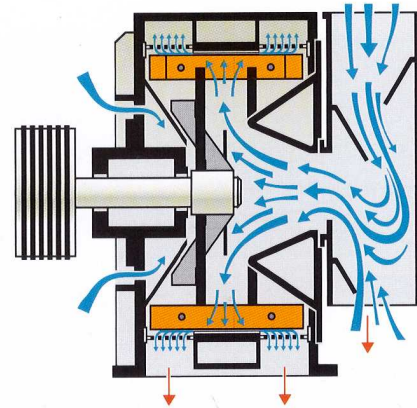

Diagram: Air flow in the Pallmann double stream mill PSKM

stream guides the feed material through this zone of intensive turbulence in axial direction or in the cross stream depending on the profile used on the grinding track. The material is reduced in the high velocity air stream by repeated impact onto the impeller wear plates and the grinding track profile. Through the air guide and within the flow channels of the grinding track a cross-stream sifting is achieved. Discharging of finished product takes place only after the dragging force of the air exceeds the kinetic rebound energy applied to the particles. In the area of this actual flow the percentage of mechanical friction is extremely small resulting in an extended service life of impeller wear plates and refining elements.

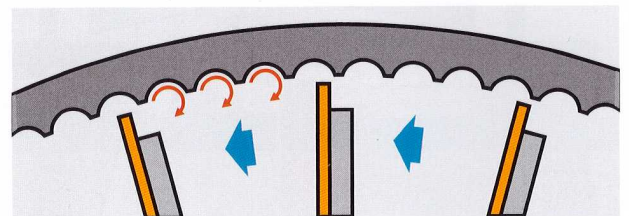
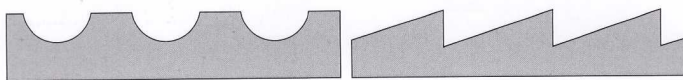
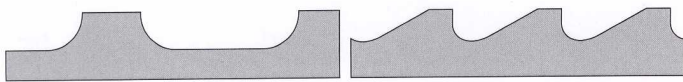
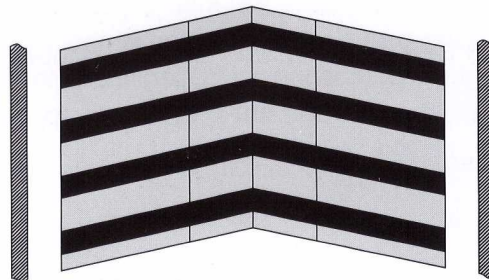
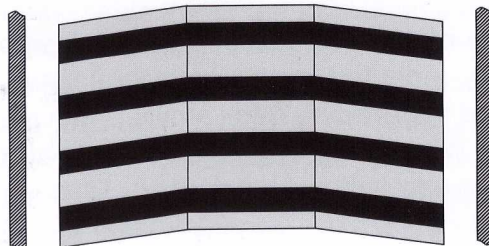
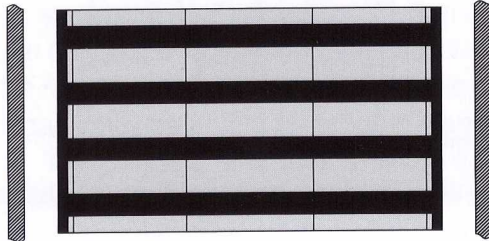
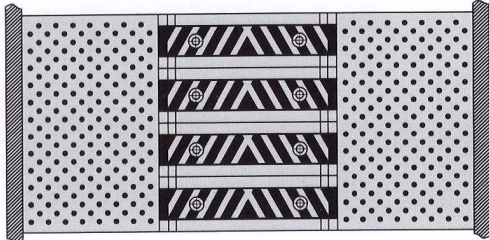

Diagram: Size reduction on the grinding track by high turbulent air in a cross stream

Double Stream Mill PSKM



Standard grinding track equipped with V-grooved ledges and screen rings

For the preparation of screen overs or rejects from the air grader into high quality surface material the PSKM double stream mill typically will be equipped with the above grinding track configuration.

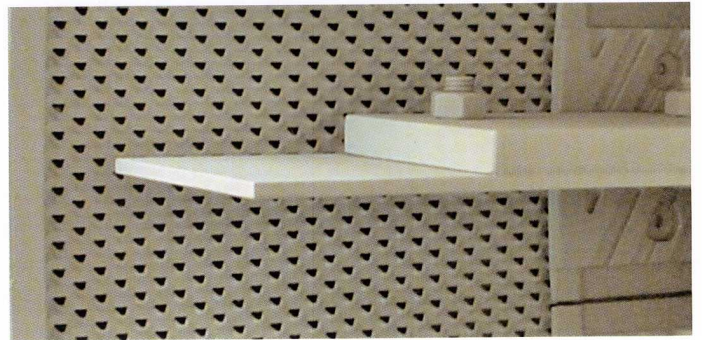

Wide grinding tracks without screen rings

Special wide grinding tracks are used for coarse and fine preparation of moist and dry materials. A variety of different grinding track profiles is available which can be bolted down onto the grinding track under different angles depending on the requested finished product characteristics. The wide grinding track is divided in three equal sections where the individual refining elements are bolted onto allowing easy adjustment of the total grinding track profile to changing feed material conditions or finished product requirements.

Different grinding profiles for each requirement

Size reduction is done exclusively on the central grinding track which is insensitive to wear. The screen rings at both sides of the grinding track give large size flakes their final shape, and work as a subsequent sifter. The finished product is of uniform size and can be used directly in production without additional sifting.

Double Stream Mill PSKM

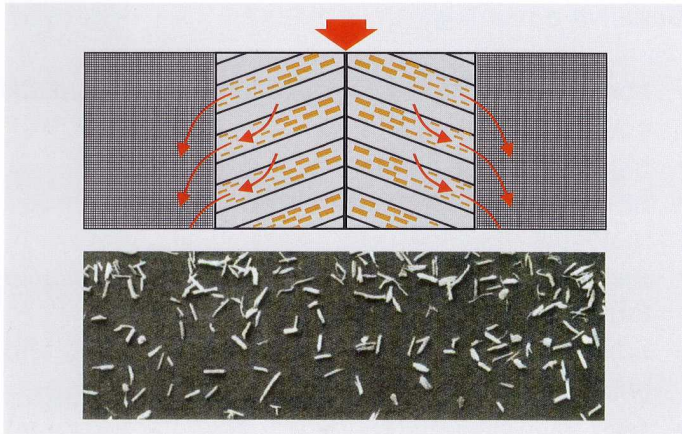

Example: Out of the V

The optimum relation between dimensions of grinding track and screen surface, width of the impeller wear plates and installed motor power results in a large throughput capacity and high grinding efficiency of the Pallmann double stream mill, combined with a minimum specific power requirement. Besides the low cost for wear parts due to the specific type of size reduction, these are the main factors for the economical preparation of homogeneous surface particles, using the proved size reduction principle of the Pallmann double stream mill. Working out of the V means reduction of the retention time of the feed material on the central grinding track resulting in a coarser finished product.

Adjustment of Fineness

By changing the height of the wear plates (dimensions b) the distance to the grinding track can be adjusted (dimension c) as per requirement. Standard c-distances are (4), 6, 8 and 10 mm.

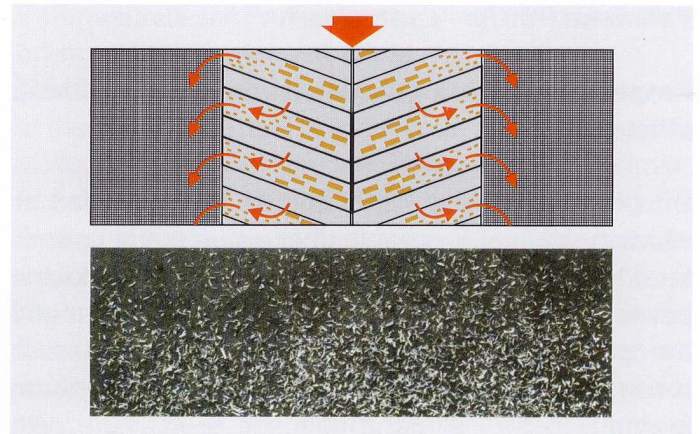

Example: Into the V

Immediately after the feed material has been reduced on the grinding track the fine particles are discharged through relatively coarse screen rings positioned on each side of the grinding track. Through adjustment of the air flow, selection of the grinding track profile and gap to the beater plate (c) and selection of the mesh size of the screen rings, the degree of preparation can be controlled as desired. These adjusting possibilities allow easy adaptation of the Pallmann double stream mill to the surface material quality required for an engineered particle board. Working into the V means a finer finished product.

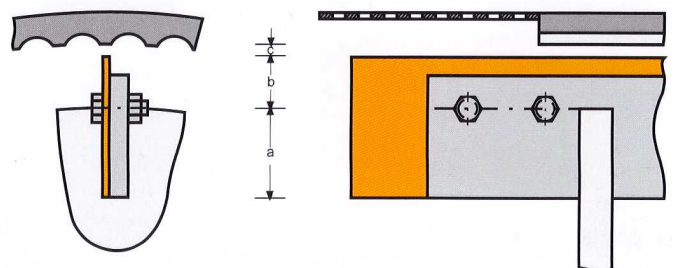

Double Stream Mill PSKM

Pallmann PSKM – Examples for Installation

Proper installation guarantees optimum machine efficiency

Double stream mills PSKM should always be fed by vibratory feeders in order to make sure that a uniform feed rate and optimum use of the installed electric power can be achieved. Between the vibrofeeder and the gravity separator feed chute of the mill it is recommended to install either a self-cleaning drum magnet or the Pallmann cascade feed chute with integrated drawer type permanent plate magnets which can be cleaned in regular intervals during operation. The air flow generated by the double stream mill and the final product should be picked up by a pneumatic discharge system. The double stream mill can be installed either on a flat concrete floor, if lateral product discharge has been chosen, on a steel frame or on concrete foundations with discharge pit if the standard design with product discharge straight downward is chosen.

Decisive advantages:

- homogenous material preparation with low specific power requirements
- high throughput capacities
- all-purpose and adaptable for different infeed materials
- easy adjusting to the required finesses by simple turning of V-grooved ledges
- adjusting of the grinding gap, srec opening and impeller speed
- easy exchange of the grinding track
- alternative material discharge vertically to below or lateral
- high availability and very low maintenance costs

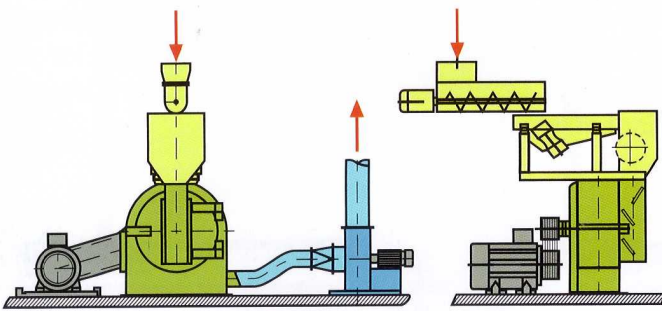

Diagram: Installation at ground level

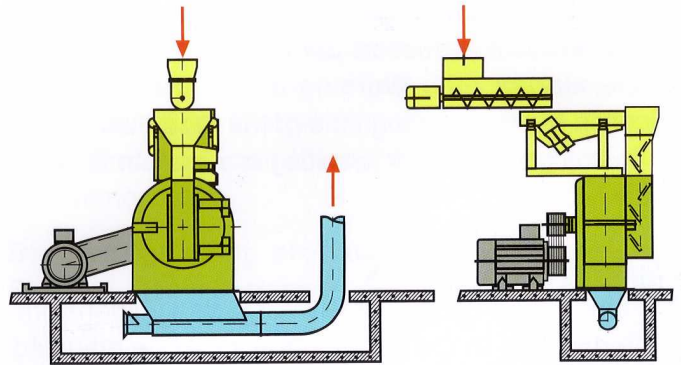
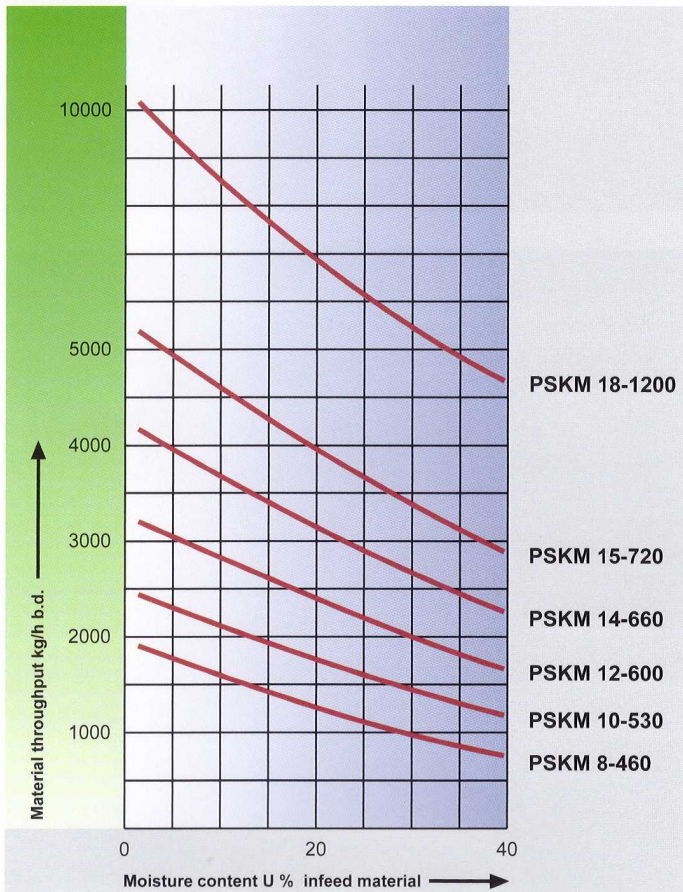

Diagram: Installation on concrete foundation with discharge pit

Type		PSKM 8-460	PSKM 10-530	PSKM 12-600	PSKM 14-660	PSKM 15-720	PSKM 18-1200
Diameter of the grinding track	mm	800	1000	1200	1400	1500	1800
Width of the grinding track	mm	150	180	210	230	250	460
Width of the screen ring	mm	2 x 140	2 x 160	2 x 180	2 x 200	2 x 220	2 x 370
Net weight without motor	approx. kg	1200	1800	2800	3800	4700	13300
Shipping space	approx. m ³	1,8	3,5	5,5	8,0	11,0	26,0
Recommended motor	kW	90 - 110	132 - 200	200 - 315	250 - 400	315 - 500	630 - 1000
Airflow through machine	approx. m ³ /h*	6000	7800	9000	12000	15000	30000

* with CON 3.0mm screen

Double Stream Mill PSKM



Pallmann PSKM Performance Diagram depending on moisture content of wood

The throughput rate depends on the moisture content of the wood, the width of the screen rings, the species of wood, the shape of the feed material (see adjustment factors a, b, c). In addition, when determining the throughput rate, the required fineness of the reduced material, depending on the grinding track profile, is important. The table shown is based on coniferous flat flakes, a V-grooved grinding profile and 3 mm conidur screens. The figures shown are approximate figures only. In case of any doubt we recommend free of charge performance trials with your original feed material in our modern research and development center. Tests will be done on production size equipment only and will deliver to you reliable data.

Adjustment factors:

a) for screen width		Factor
Conidur	4.0 mm	1.5
Conidur	3.5 mm	1.3
Conidur	3.0 mm	1.0
Conidur	2.5 mm	0.9
Conidur	2.0 mm	0.8
Conidur	1.5 mm	0.7
Conidur	1.0 mm	0.6
Slotted screen	2 x 20 mm	0.9
Slotted screen	2 x 30 mm	1.1
Slotted screen	2 x 40 mm	1.3

b) for type of wood		Factor
poplar		0.7
alder, light pine wood		0.8
spruce, fir, pine		1.0
beech, birch, oak		1.2

c) for shape of feeding flake		Factor
flat flakes		1.0
sawmill flakes		1.1
planer shavings		0.8 - 0.9
splinters		0.7 - 0.8
veneer waste, pre-chipped		0.6 - 0.7
chips, approx. 25 mm		0.5 - 0.6

Example:

Moisture content:	u = 20%
Screen mesh size:	2.0 Conidur (factor = 0.8)
Type of wood:	beech (factor = 1.2)
Flake shape:	sawmill flakes (factor = 1.1)
PSKM 14-660 Table value:	3100 kg/h b.d. con u = 12%
3100 kg/h b.d. x 0.8 x 1.2 x 1.1 = 3273 kg/h b.d.	



The Pallmann Group of Companies

The Pallmann Group is the leading manufacturer for size reduction machinery in the wood products industry. The Pallmann Maschinenfabrik designs, manufactures and supplies tailor-made individual or complete solutions for the processing of raw material for MDF, OSB, particle board, waste wood and annual plants. At the headquarters in Zweibrücken, the Pallmann company runs the world's largest research and development plant as well as a training and service centre. More than 100 test machines are available for the preparation of various raw materials with subsequent laboratory analysis on industrial scale.

In addition to the manufacturing plants in Europe, North and South America, the Pallmann group has a worldwide sales and service network.



The Pallmann Program

Engineering and Service:

Design and manufacturing
Research & development
Tests at industrial scale
Laboratory analysis
Worldwide service
Spare parts
Control systems
Process monitoring
Set-up & commissioning
Refurbishment

System solutions for:

Flake production
Fibre production
Strand production
Recycling
Annual plants preparation

Components:

Debarkers
Universal flakers
Long log flakers
Disc chippers
Drum chippers
Knife ring flakers
Double stream mills
Hammer mills
Drum shredders
Bale breakers
Depithers
Refiners
Chip washing systems
Re-chippers
Pre-crushers
Impact hammer mills
Screen ring mills
Wing beater mills

Pallmann Maschinenfabrik GmbH & Co. KG
Wolfslochstraße 51
66482 Zweibrücken
Germany
Phone +49 6332 802 0
Fax +49 6332 802 511
E-mail: wood@pallmann-online.de
<http://www.pallmann.de>

Pallmann America Inc.
6420 -A1, Rea Rd. Suite 335 Charlotte
NC 28277
USA
Phone +1 704 543 4400
Fax +1 704 543 5580
E-mail: sales@pallmannamerica.com
<http://www.pallmannamerica.com>

Pallmann do Brasil ind. e Com Ltda
Av. Presidente Juscelino, 11 56
09950-370 Diadema S.P.
Brasil
Phone +55 11 4075 3044
Fax +55 11 4075 4968
E-mail: pallmann@pallmann.com.br
<http://www.pallmann.com.br>

Pallmann Beijing Office
Unit 13, 6th Floor of Tower A
Beijing Cofco Plaza
No.8, Jianguomennei Dajie, Dongcheng District
Beijing, China
Phone +86 10851 16826
Fax +86 10851 16825
E-mail: info@pallmann.com.cn

PALLMANN Moskau Office
Leninskij prospekt dom 158
Office Nr. 206
119571 Moskau
Russland
Phone 007 495 232 15 21
Fax 007 495 232 15 22
E-mail: info@pallmann.ru